

INFD065C150BGC: DFN8 8x8 Cascode GaN HEMT

Description

INFD065C150BGC is a normally-off GaN High electron mobility transistor (HEMT) device using the cascode configuration, which provides high breakdown voltage, high current and high operating speed which is suitable for high power applications.

Key Specifications

Part Number	INFD065C150BGC
$V_{DSS, min.}$	650V
$V_{(TR)DSS, min.}$	800V
$R_{DS(ON), typ.}$	150m Ω
$Q_G, typ.$	14.3nC
Package	DFN8 8 x 8 mm

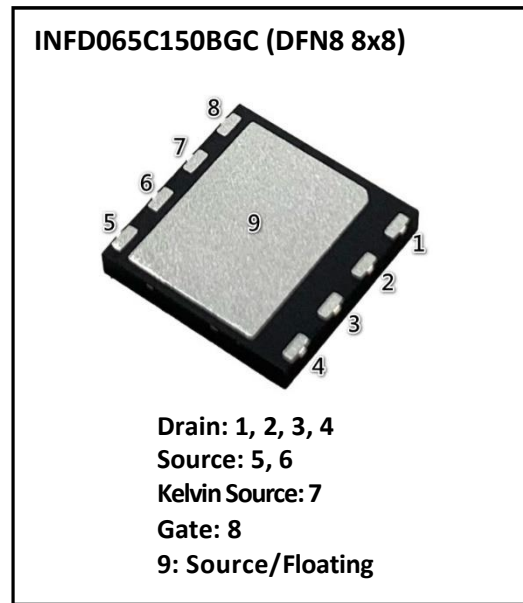

Features

- Gate drive voltage compatibility (-20V to +20V)
- High operating frequency
- Low Q_{rr}

Applications

- Switch Mode Power Supplies (SMPS)
- AC-DC/ DC-DC Converters
- Motor Drives

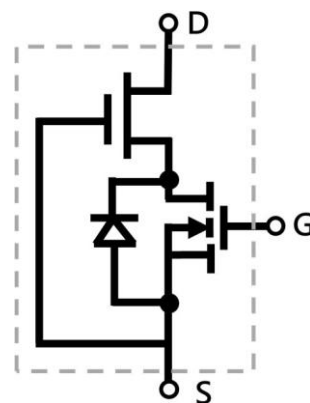

Cascode Device Structure

Table of Contents

	Description	1
	Key Specifications.....	1
	Features	1
	Applications.....	1
	Table of Contents	2
1	Electrical Characteristics and Parameters	3
2	Typical Characteristic Curves.....	4
3	Package Outline Dimensions.....	5
4	Reflow Soldering Profile.....	9
5	Change Log.....	12

1- Electrical Characteristics

➤ **Table 1 Absolute maximum ratings**

Symbol	Parameter		Value	Unit
V_{DSS}	Drain-source voltage		650	V
$V_{(TR)DSS}$	Transient drain to source voltage ^a		800	V
V_{GSS}	Gate- source voltage		-20V ~ +20V	V
I_D	Drain current (continuous) at $T_C = 25^\circ\text{C}$ operation		12	A
	Drain current (continuous) at $T_C = 100^\circ\text{C}$ operation		8	A
I_{DM}	Pulsed drain current (pulse width: 10 μs)		21	A
T_C	Operating temperature	Case	-55 to +150	$^\circ\text{C}$
T_J		Junction	-55 to +150	$^\circ\text{C}$
T_S	Storage temperature		-55 to +150	$^\circ\text{C}$
T_{SOLD}	Soldering peak temperature ^b		260	$^\circ\text{C}$

a. In off-state, spike duty cycle $D < 0.01$, spike duration $< 1\mu\text{s}$

b. For 10 sec., 1.6mm from the case

➤ **Table 2 Thermal Characteristics**

Symbol	Parameter	Value	Unit
$R_{\theta JA}$	Thermal resistance junction-ambient	53	$^\circ\text{C}/\text{W}$
$R_{\theta JC}$	Thermal resistance junction-case	2.7	$^\circ\text{C}/\text{W}$

➤ Table 3 Electrical Characteristics ($T_{CASE} = 25\text{ °C}$ unless otherwise stated)

Symbol	Parameter	Conditions	Values			Unit
			min.	typ.	max.	
$V_{(BL)DSS}$	Drain-source voltage	$V_{GS}=0V$	650	-	-	V
$V_{GS(th)}$	Gate threshold voltage	$V_{DS}=10V, I_D=0.5mA$	1.2	1.6	2.0	V
$R_{DS(on)}$	Static drain-source on-resistance	$V_{GS}=10V, I_D=8.5A, T_J=25\text{ °C}$	-	150	181	mΩ
		$V_{GS}=10V, I_D=8.5A, T_J=150\text{ °C}$	-	298	-	
I_{DSS}	Drain-source leakage current	$V_{GS}=0V, V_{DS}=650V, T_J=25\text{ °C}$	-	2	20	μA
		$V_{GS}=0V, V_{DS}=650V, T_J=150\text{ °C}$	-	10	-	
I_{GSS}	Gate-to-source forward leakage current	$V_{GS}=20V$	-	-	100	nA
	Gate-to-source reverse leakage current	$V_{GS}=-20V$	-	-	-100	
C_{ISS}	Input capacitance	$V_{GS}=0V, V_{DS}=400V, f=1MHz$	-	2537	-	pF
C_{OSS}	Output capacitance		-	17.3	-	
C_{RSS}	Reverse transfer capacitance		-	2.05	-	
Q_G	Gate charge	$V_{GS}=0\sim 10V, V_{DS}=400V, I_{DS}=8.5A$	-	14.3	-	nC
Q_{GS}	Gate-source charge		-	2.1	-	
Q_{OSS}	Output charge	$V_{GS}=0V, V_{DS}=0\sim 400V$	-	12.5	-	nC
$t_{D(on)}$	Turn-on delay time	$V_{DS}=400V, V_{GS}=0\text{ to }10V, I_{DS}=2A, R_G=10\Omega$	-	10.6	-	ns
$t_{D(off)}$	Turn-off delay time		-	9.7	-	

2- Typical Characteristic Curves

3- Package Outline Dimensions

INFD065C150BGC (DFN8 8x8)

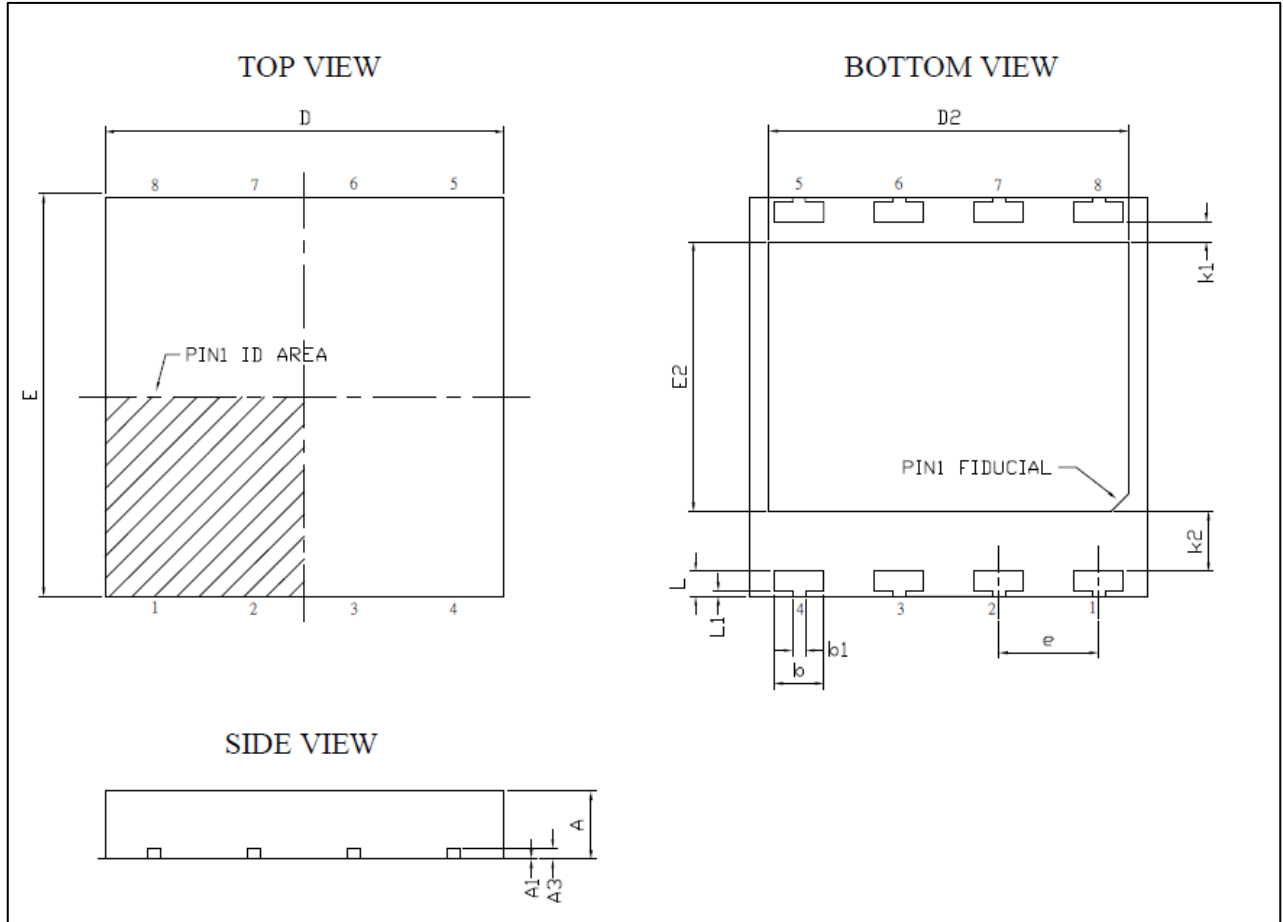

➤ Table 5 Dimension of INFD065C150BGC

Symbol	DIMENSION (MM)			Symbol	DIMENSION (MM)		
	MIN.	NOM.	MAX.		MIN.	NOM.	MAX.
A	1.20	1.25	1.30	b	2.20	2.25	2.30
A1	0	0.02	0.05	b1	0.30	0.40	0.50
A3	0.203 REF			L	0.70	0.80	0.90
D	7.90	8.00	8.10	L1	0.05	0.10	0.15
E	7.90	8.00	8.10	e	4.75 BSC		
D2	7.05	7.20	7.35	K	2.00	2.10	2.20
E2	4.70	4.80	4.90				

4- Reflow Soldering Profile

Recommended Reflow Soldering Condition (IPC/JEDEC J-STD-020D.1)

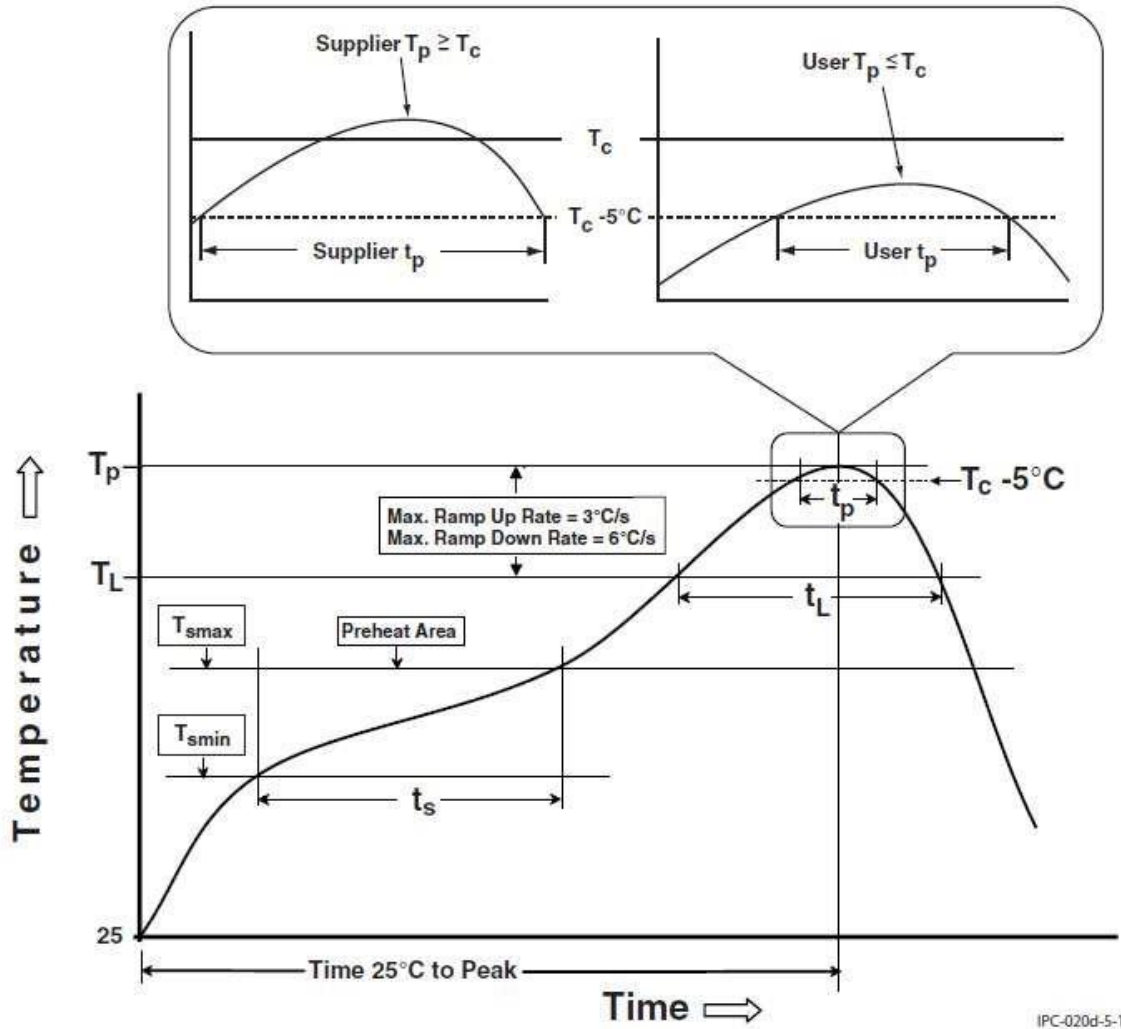

➤ **Table 6 Recommended Reflow Soldering Condition**

Profile Feature	Pb-Free Assembly
Preheat/Soak	
Temperature Min (T_{smin})	150°C
Temperature Max (T_{smax})	200°C
Time (t_s) from (T_{smin} to T_{smax})	60-120 seconds
Ramp-up rate (T_L to T_P)	3°C/second max.
Liquidous temperature (T_L)	217°C
Time (t_L) maintained above T_L	60-150 seconds
Time (t_p)* within 5°C of the specified classification temperature (T_c)**, see Reflow Soldering Profile above.	30* seconds
Ramp-down rate (T_p to T_L)	6°C/second max.
Time 25°C to peak temperature	8 minutes max.

(t_p)* The highest temperature that an individual package body reaches during MSL classification.

(T_c)** The maximum body temperature at which the component manufacturer guarantees the component MSL as noted on the caution and/or bar code label (per J-STD-033).

30* seconds Reflow profiles in this document are for classification/preconditioning and are not meant to specify board assembly profiles. Actual board assembly profiles should be developed based on specific process needs and board designs and should not exceed the parameters in **Table 5**.

For example, if T_c is 260 °C and time t_p is 30 seconds, this means the following for the supplier and the user.

For a supplier: The peak temperature must be at least 260 °C. The time above 255 °C must be at least 30

seconds. For a user: The peak temperature must not exceed 260 °C. The time above 255 °C must not exceed 30 seconds

5- Change Log

Version	Date	Description
1.01	May 20, 2024	Initial version

- **Note:** iFINITYrf Communication reserves the right to revise products and/or specifications without notice.